

# SN54132, SN54LS132, SN54S132, SN74132, SN74LS132, SN74S132 QUADRUPLE 2-INPUT POSITIVE-NAND SCHMITT TRIGGERS

SDLS047 - DECEMBER 1983 - REVISED MARCH 1988

- Operation from Very Slow Edges
- Improved Line-Receiving Characteristics
- High Noise Immunity

## description

Each circuit functions as a 2-input NAND gate, but because of the Schmitt action, it has different input threshold levels for positive ( $V_{T+}$ ) and for negative going ( $V_{T-}$ ) signals.

These circuits are temperature-compensated and can be triggered from the slowest of input ramps and still give clear, jitter-free output signals.

The SN54132, SN54LS132, and SN54S132 are characterized for operation over the full military temperature range of  $-55^{\circ}\text{C}$  to  $125^{\circ}\text{C}$ . The SN74132, SN74LS132, and SN74S132 are characterized for operation from  $0^{\circ}\text{C}$  to  $70^{\circ}\text{C}$ .

## logic diagram (positive logic)

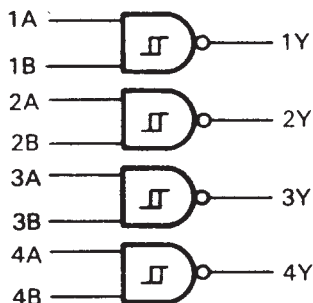

SN54132, SN54LS132, SN54S132 . . . J OR W PACKAGE  
SN74132 . . . N PACKAGE  
SN74LS132, SN74S132 . . . D OR N PACKAGE

(TOP VIEW)

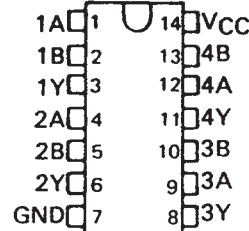

SN54LS132, SN54S132 . . . FK PACKAGE

(TOP VIEW)

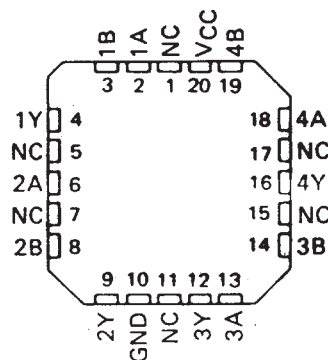

NC-No internal connection

## logic symbol†



positive logic:  $Y = \overline{AB}$  or  $Y = \overline{A} + \overline{B}$

†This symbol is in accordance with ANSI/IEEE Std 91-1984 and IEC Publication 617-12.  
Pin numbers shown are for D, J, N, and W packages.

# SN54132, SN54LS132, SN54S132, SN74132, SN74LS132, SN74S132 QUADRUPLE 2-INPUT POSITIVE-NAND SCHMITT TRIGGERS

SDLS047 – DECEMBER 1983 – REVISED MARCH 1988

## schematics

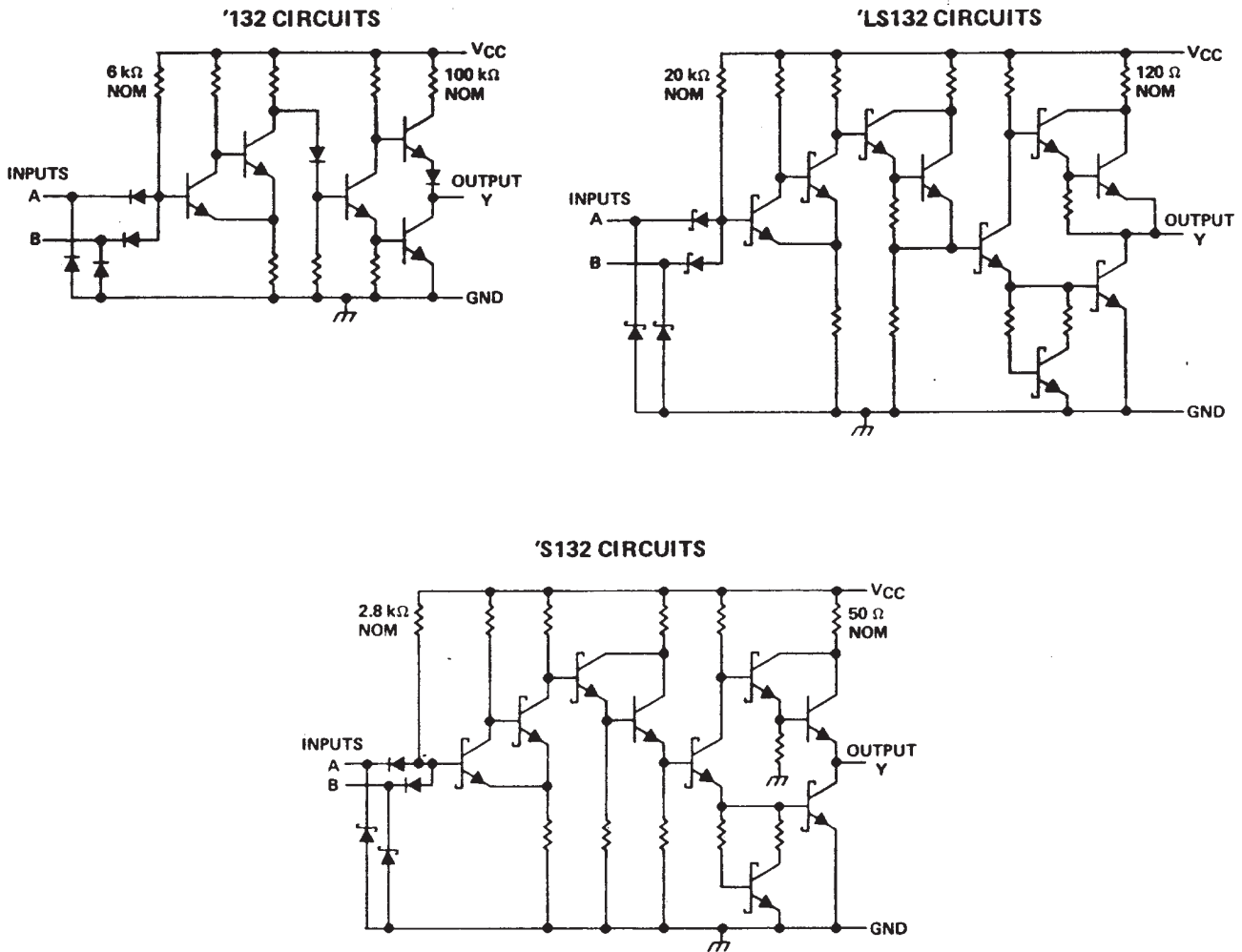

Resistor values shown are nominal.

### absolute maximum ratings over operating free-air temperature range (unless otherwise noted)

Supply voltage, $V_{CC}$ (see Note 1).....	7 V
Input voltage: '132, 'S132.....	5.5 V
'LS132.....	7 V
Operating free-air temperature: SN54'.....	-55°C to 125°C
SN74'.....	0°C to 70°C
Storage temperature range.....	-65°C to 150°C

NOTE 1: Voltages values are with respect to network ground terminal.



POST OFFICE BOX 655303 • DALLAS, TEXAS 75265

# SN54132, SN74132

## QUADRUPLE 2-INPUT POSITIVE-NAND SCHMITT TRIGGERS

SDLS047 – DECEMBER 1983 – REVISED MARCH 1988

### recommended operating conditions

	SN54132			SN74132			UNIT
	MIN	NOM	MAX	MIN	NOM	MAX	
V <sub>CC</sub> Supply voltage	4.5	5	5.5	4.75	5	5.25	V
I <sub>OH</sub> High-level output current			-0.8			-0.8	mA
I <sub>OL</sub> Low-level output current			16			16	mA
T <sub>A</sub> Operating free-air temperature	-55		125	0		70	°C

### electrical characteristics over recommended operating free-air temperature range (unless otherwise noted)

PARAMETER	TEST CONDITIONS†	MIN	TYP‡	MAX	UNIT
V <sub>T+</sub>	V <sub>CC</sub> = 5 V	1.5	1.7	2	V
V <sub>T-</sub>	V <sub>CC</sub> = 5 V	0.6	0.9	1.1	V
V <sub>hys</sub> (V <sub>T+</sub> - V <sub>T-</sub> )	V <sub>CC</sub> = 5 V	0.4	0.8		V
V <sub>IK</sub>	V <sub>CC</sub> = MIN, I <sub>I</sub> = -12 mA			-1.5	V
V <sub>OH</sub>	V <sub>CC</sub> = MIN, V <sub>I</sub> = 0.6 V, I <sub>OH</sub> = -0.8 mA	2.4	3.4		V
V <sub>OL</sub>	V <sub>CC</sub> = MIN, V <sub>I</sub> = 2 V, I <sub>OL</sub> = 16 mA		0.2	0.4	V
I <sub>T+</sub>	V <sub>CC</sub> = 5 V, V <sub>I</sub> = V <sub>T+</sub>	-0.43			mA
I <sub>T-</sub>	V <sub>CC</sub> = 5 V, V <sub>I</sub> = V <sub>T-</sub>	-0.56			mA
I <sub>I</sub>	V <sub>CC</sub> = MAX, V <sub>I</sub> = 5.5 V			1	mA
I <sub>IH</sub>	V <sub>CC</sub> = MAX, V <sub>I</sub> = 2.4 V			40	μA
I <sub>IL</sub>	V <sub>CC</sub> = MAX, V <sub>IL</sub> = 0.4 V	-0.8		-1.2	mA
I <sub>OS</sub> §	V <sub>CC</sub> = MAX	-18		-55	mA
I <sub>CCH</sub>	V <sub>CC</sub> = MAX		15	24	mA
I <sub>CCL</sub>	V <sub>CC</sub> = MAX		26	40	mA

† For conditions shown as MIN or MAX, use the appropriate value specified under recommended operating conditions.

‡ All typical values are at V<sub>CC</sub> = 5 V, T<sub>A</sub> = 25°C.

§ Not more than one output should be shorted at a time.

### switching characteristics, V<sub>CC</sub> = 5 V, T<sub>A</sub> = 25°C (see figure 1)

PARAMETER	FROM (INPUT)	TO (OUTPUT)	TEST CONDITIONS	MIN	TYP	MAX	UNIT
t <sub>PLH</sub>	Any	Y	R <sub>L</sub> = 400 Ω, C <sub>L</sub> = 15 pF		15	22	ns
t <sub>PHL</sub>					15	22	ns



# SN54LS132, SN74LS132 QUADRUPLE 2-INPUT POSITIVE-NAND SCHMITT TRIGGERS

SDLS047 – DECEMBER 1983 – REVISED MARCH 1988

## recommended operating conditions

	SN54LS132			SN74LS132			UNIT
	MIN	NOM	MAX	MIN	NOM	MAX	
V <sub>CC</sub> Supply voltage	4.5	5	5.5	4.75	5	5.25	V
I <sub>OH</sub> High-level output current	-0.4			-0.4			mA
I <sub>OL</sub> Low-level output current	4			8			mA
T <sub>A</sub> Operating free-air temperature	-55	125		0	70		°C

## electrical characteristics over recommended operating free-air temperature range (unless otherwise noted)

PARAMETER	TEST CONDITIONS†	SN54LS132			SN74LS132			UNIT
		MIN	TYP‡	MAX	MIN	TYP‡	MAX	
V <sub>T+</sub>	V <sub>CC</sub> = 5 V	1.4	1.6	1.9	1.4	1.6	1.9	V
V <sub>T-</sub>	V <sub>CC</sub> = 5 V	0.5	0.8	1	0.5	0.8	1	V
V <sub>hys</sub> (V <sub>T+</sub> - V <sub>T-</sub> )	V <sub>CC</sub> = 5 V	0.4	0.8		0.4	0.8		V
V <sub>IK</sub>	V <sub>CC</sub> = MIN, I <sub>I</sub> = -18 mA	-1.5			-1.5			V
V <sub>OH</sub>	V <sub>CC</sub> = MIN, V <sub>I</sub> = 0.5 V, I <sub>OH</sub> = -0.4 mA	2.5	3.4		2.7	3.4		V
V <sub>OL</sub>	V <sub>CC</sub> = MIN, V <sub>I</sub> = 1.9 V	I <sub>OL</sub> = 4 mA		0.25	0.4		V	
		I <sub>OL</sub> = 8 mA		0.35 0.5				
I <sub>T+</sub>	V <sub>CC</sub> = 5 V, V <sub>I</sub> = V <sub>T+</sub>	-0.14			-0.14			mA
I <sub>T-</sub>	V <sub>CC</sub> = 5 V, V <sub>I</sub> = V <sub>T-</sub>	-0.18			-0.18			mA
I <sub>I</sub>	V <sub>CC</sub> = MAX, V <sub>I</sub> = 7 V	0.1			0.1			mA
I <sub>IH</sub>	V <sub>CC</sub> = MAX, V <sub>I</sub> = 2.7 V	20			20			μA
I <sub>IL</sub>	V <sub>CC</sub> = MAX, V <sub>IL</sub> = 0.4 V	-0.4			-0.4			mA
I <sub>OS</sub> §	V <sub>CC</sub> = MAX	-20	-100		-20	-100		mA
I <sub>CCH</sub>	V <sub>CC</sub> = MAX	5.9 11		5.9 11		mA		
I <sub>CCL</sub>	V <sub>CC</sub> = MAX	8.2 14		8.2 14		mA		

† For conditions shown as MIN or MAX, use the appropriate value specified under recommended operating conditions.

‡ All typical values are at V<sub>CC</sub> = 5 V, T<sub>A</sub> = 25°C.

§ Not more than one output should be shorted at a time, and duration of the short-circuit should not exceed one second.

## switching characteristics, V<sub>CC</sub> = 5 V, T<sub>A</sub> = 25°C (see figure 1)

PARAMETER	FROM (INPUT)	TO (OUTPUT)	TEST CONDITIONS	MIN	TYP	MAX	UNIT
t <sub>PLH</sub>	Any	Y	R <sub>L</sub> = 2 kΩ, C <sub>L</sub> = 15 pF	15	22	ns	
t <sub>PHL</sub>				15	22		



# SN54S132, SN74S132

## QUADRUPLE 2-INPUT POSITIVE-NAND SCHMITT TRIGGERS

SDLS047 – DECEMBER 1983 – REVISED MARCH 1988

### recommended operating conditions

	SN54S132			SN74S132			UNIT
	MIN	NOM	MAX	MIN	NOM	MAX	
$V_{CC}$ Supply voltage	4.5	5	5.5	4.75	5	5.25	V
$I_{OH}$ High-level output current			-1			-1	mA
$I_{OL}$ Low-level output current			20			20	mA
$T_A$ Operating free-air temperature	-55		125	0		70	°C

### electrical characteristics over recommended operating free-air temperature range (unless otherwise noted)

PARAMETER	TEST CONDITIONS†	SN54S132			SN74S132			UNIT
		MIN	TYP‡	MAX	MIN	TYP‡	MAX	
$V_{T+}$	$V_{CC} = 5\text{ V}$	1.6	1.77	1.9	1.6	1.77	1.9	V
$V_{T-}$	$V_{CC} = 5\text{ V}$	1.1	1.22	1.4	1.1	1.22	1.4	V
$V_{hys}$ ( $V_{T+} - V_{T-}$ )	$V_{CC} = 5\text{ V}$	0.2	0.55		0.2	0.55		V
$V_{IK}$	$V_{CC} = \text{MIN}$ , $I_I = -18\text{ mA}$			-1.2			-1.2	V
$V_{OH}$	$V_{CC} = \text{MIN}$ , $V_I = 1.1\text{ V}$ , $I_{OH} = -1\text{ mA}$	2.5	3.4		2.7	3.4		V
$V_{OL}$	$V_{CC} = \text{MIN}$ , $V_I = 1.9\text{ V}$ , $I_{OL} = 20\text{ mA}$			0.5			0.5	V
$I_{T+}$	$V_{CC} = 5\text{ V}$ , $V_I = V_{T+}$		-0.9			-0.9		mA
$I_{T-}$	$V_{CC} = 5\text{ V}$ , $V_I = V_{T-}$		-1.1			-1.1		mA
$I_I$	$V_{CC} = \text{MAX}$ , $V_I = 5.5\text{ V}$			1			1	mA
$I_{IH}$	$V_{CC} = \text{MAX}$ , $V_I = 2.7\text{ V}$			50			50	$\mu\text{A}$
$I_{IL}$	$V_{CC} = \text{MAX}$ , $V_{IL} = 0.5\text{ V}$			-2			-2	mA
$I_{OS}\S$	$V_{CC} = \text{MAX}$	-40		-100	-40		-100	mA
$I_{CCH}$	$V_{CC} = \text{MAX}$		28	44		28	44	mA
$I_{CCL}$	$V_{CC} = \text{MAX}$		44	68		44	68	mA

† For conditions shown as MIN or MAX, use the appropriate value specified under recommended operating conditions.

‡ All typical values are at  $V_{CC} = 5\text{ V}$ ,  $T_A = 25^\circ\text{C}$ .

§ Not more than one output should be shorted at a time, and duration of the short-circuit should not exceed one second.

### switching characteristics, $V_{CC} = 5\text{ V}$ , $T_A = 25^\circ\text{C}$ (see figure 1)

PARAMETER	FROM (INPUT)	TO (OUTPUT)	TEST CONDITIONS	MIN	TYP	MAX	UNIT
$t_{PLH}$	A or B	Y	$R_L = 280\ \Omega$ , $C_L = 15\text{ pF}$		7	10.5	ns
$t_{PHL}$					8.5	13	ns



**SN54132, SN54LS132, SN54S132,  
SN74132, SN74LS132, SN74S132  
QUADRUPLE 2-INPUT POSITIVE-NAND SCHMITT TRIGGERS**

SDLS047 – DECEMBER 1983 – REVISED MARCH 1988

**PARAMETER MEASUREMENT INFORMATION**

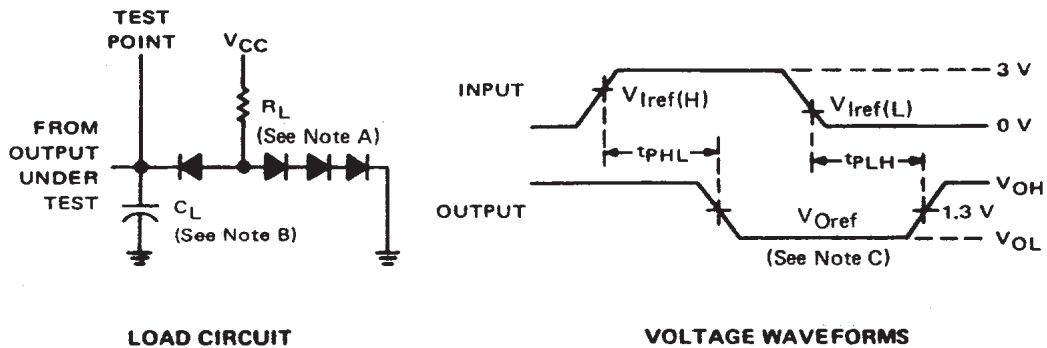

- NOTES: A. All diodes are 1N3064 or equivalent.  
 B.  $C_L$  includes probe and jig capacitance.  
 C. Generator characteristics and reference voltages are:

	Generator Characteristics				Reference Voltages		
	$Z_{out}$	PRR	$t_r$	$t_f$	$V_{I\ ref(H)}$	$V_{I\ ref(L)}$	$V_{O\ ref}$
SN54'/SN74'	50	1 MHz	10 ns	10 ns	1.7 V	0.9 V	1.5 V
SN54LS'/SN74LS'	50	1 MHz	15 ns	6 ns	1.6 V	0.8 V	1.3 V
'S132	50	1 MHz	2.5 ns	2.5 ns	1.8 V	1.2 V	1.5 V

FIGURE 1

# SN54132, SN74132

## QUADRUPLE 2-INPUT POSITIVE-NAND SCHMITT TRIGGERS

SDLS047 – DECEMBER 1983 – REVISED MARCH 1988

### TYPICAL CHARACTERISTICS OF '132 CIRCUITS

POSITIVE-GOING THRESHOLD VOLTAGE  
vs  
FREE-AIR TEMPERATURE

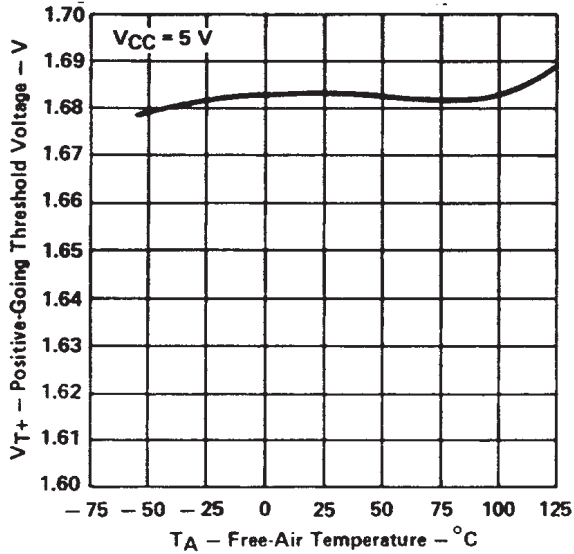

NEGATIVE-GOING THRESHOLD VOLTAGE  
vs  
FREE-AIR TEMPERATURE

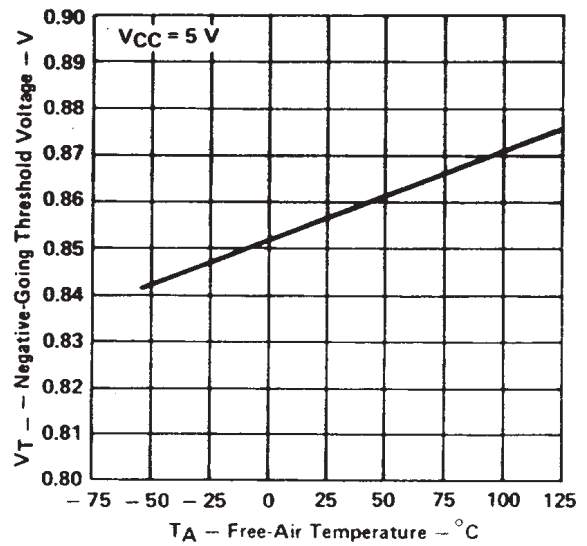

HYSTERESIS  
vs  
FREE-AIR TEMPERATURE



DISTRIBUTION OF UNITS  
FOR HYSTERESIS

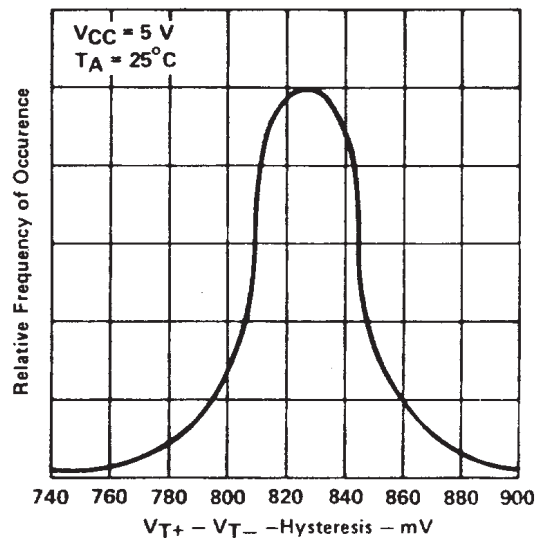

# SN54132, SN74132 QUADRUPLE 2-INPUT POSITIVE-NAND SCHMITT TRIGGERS

SDLS047 – DECEMBER 1983 – REVISED MARCH 1988

## TYPICAL CHARACTERISTICS OF '132 CIRCUITS

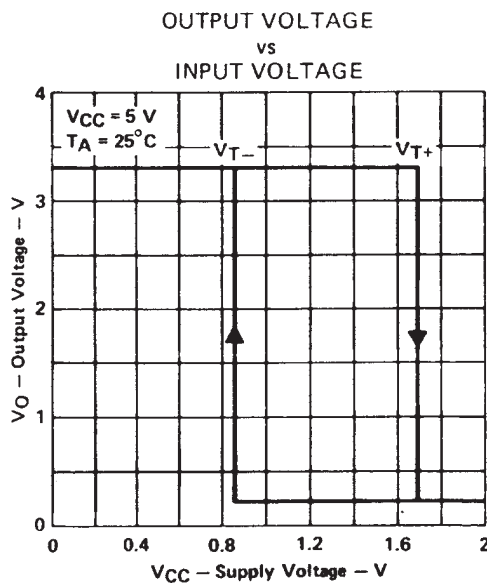
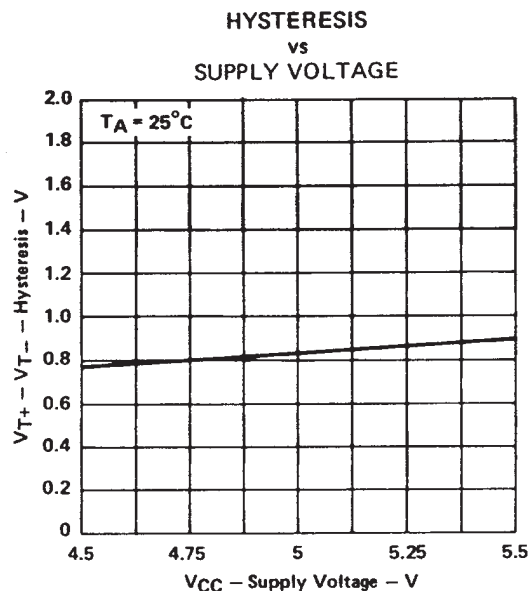

† Data for temperatures below 0°C and 70°C and supply below 4.75 V and above 5.25 V are applicable for SN54132 only.



# SN54LS132, SN74LS132

## QUADRUPLE 2-INPUT POSITIVE-NAND SCHMITT TRIGGERS

SDLS047 – DECEMBER 1983 – REVISED MARCH 1988

### TYPICAL CHARACTERISTICS OF 'LS132 CIRCUITS

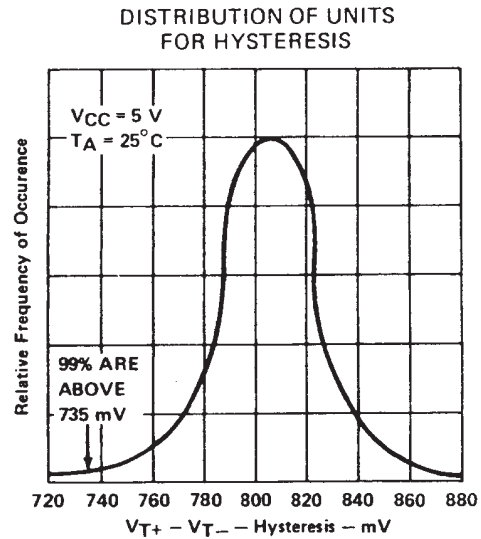
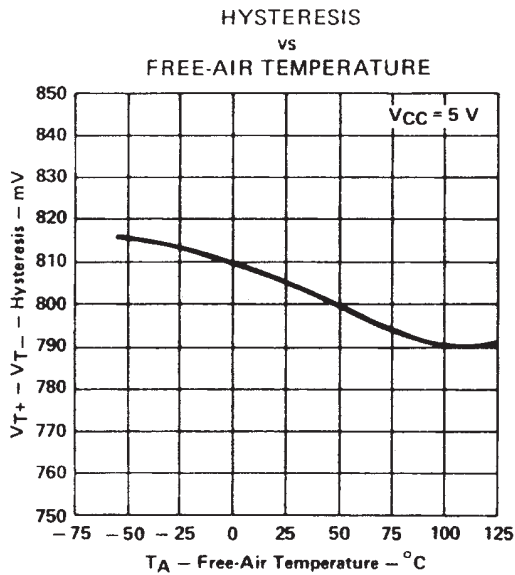
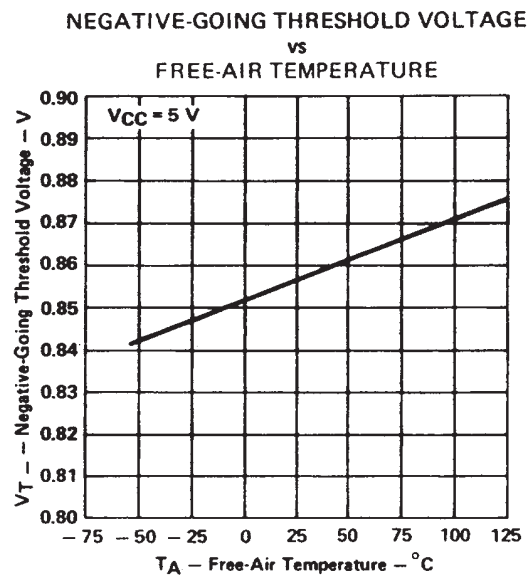
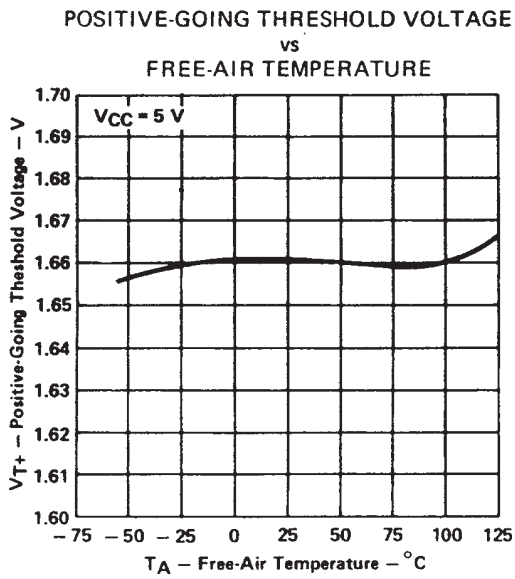

Data for temperatures below 0°C and above 70°C and supply voltages below 4.75 V and above 5.25 V are applicable for SN54LS132 only.

# SN54LS132, SN74LS132 QUADRUPLE 2-INPUT POSITIVE-NAND SCHMITT TRIGGERS

SDLS047 – DECEMBER 1983 – REVISED MARCH 1988

## TYPICAL CHARACTERISTICS OF 'LS132 CIRCUITS

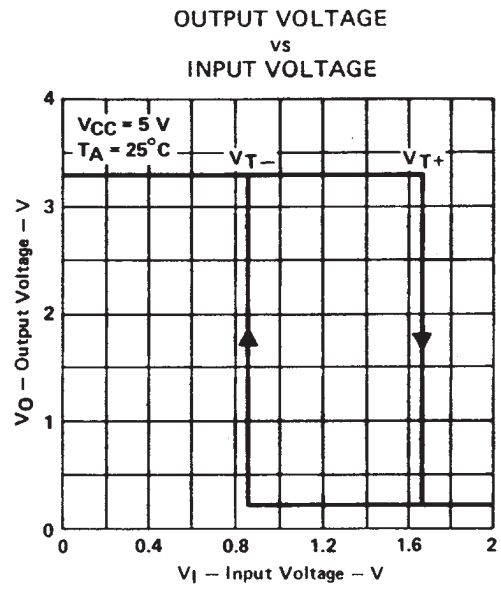

† Data for temperatures below  $0^\circ\text{C}$  and above  $70^\circ\text{C}$  and supply voltages below 4.75 V and above 5.25 V are applicable for SN54LS132 only.

SN54132, SN54LS132, SN54S132,  
SN74132, SN74LS132, SN74S132  
**QUADRUPLE 2-INPUT POSITIVE-NAND SCHMITT TRIGGERS**  
SDLS047 - DECEMBER 1983 - REVISED MARCH 1988

TYPICAL APPLICATION DATA

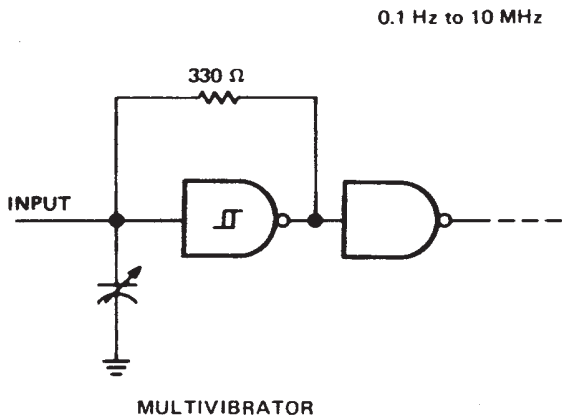
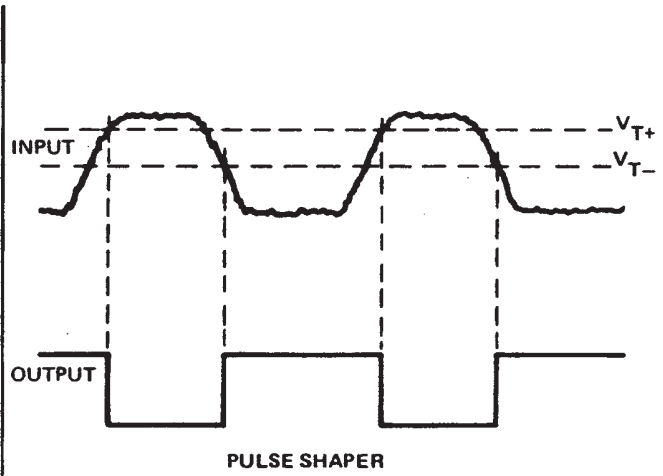
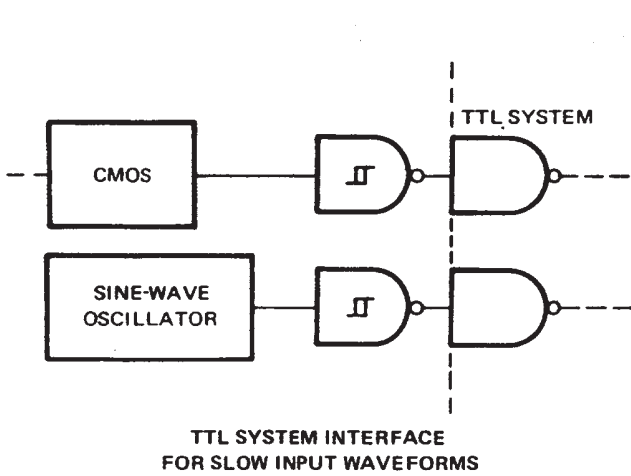

0.1 Hz to 10 MHz

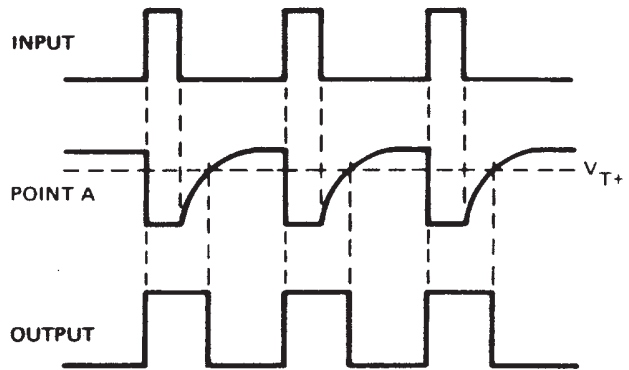
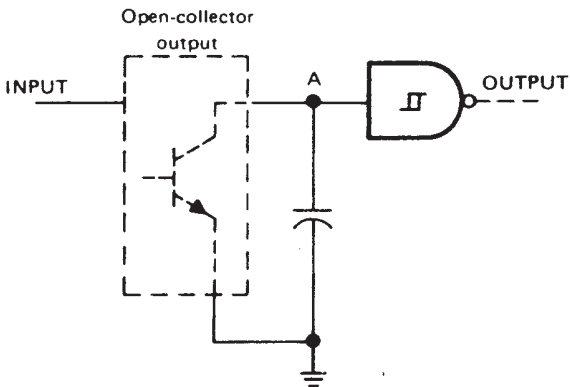
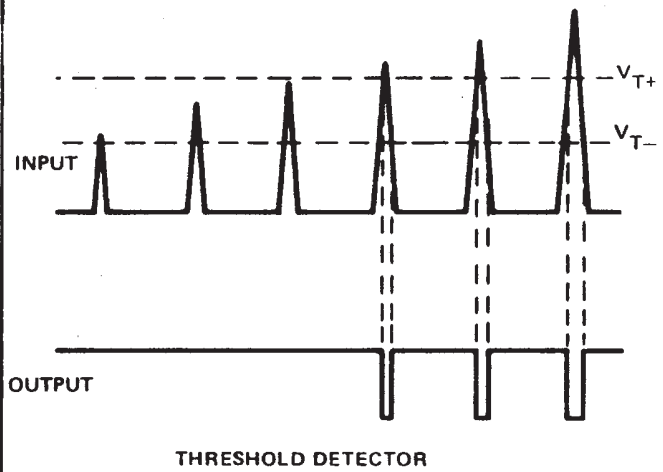

**PACKAGING INFORMATION**

Orderable Device	Status (1)	Package Type	Package Drawing	Pins	Package Qty	Eco Plan (2)	Lead finish/ Ball material (6)	MSL Peak Temp (3)	Op Temp (°C)	Device Marking (4/5)	Samples
7600401CA	ACTIVE	CDIP	J	14	25	Non-RoHS & Green	SNPB	N / A for Pkg Type	-55 to 125	7600401CA SNJ54LS132J	<a href="#">Samples</a>
7600401DA	ACTIVE	CFP	W	14	25	Non-RoHS & Green	SNPB	N / A for Pkg Type	-55 to 125	7600401DA SNJ54LS132W	<a href="#">Samples</a>
7600401DA	ACTIVE	CFP	W	14	25	Non-RoHS & Green	SNPB	N / A for Pkg Type	-55 to 125	7600401DA SNJ54LS132W	<a href="#">Samples</a>
JM38510/31303BCA	ACTIVE	CDIP	J	14	25	Non-RoHS & Green	SNPB	N / A for Pkg Type	-55 to 125	JM38510/ 31303BCA	<a href="#">Samples</a>
JM38510/31303BCA	ACTIVE	CDIP	J	14	25	Non-RoHS & Green	SNPB	N / A for Pkg Type	-55 to 125	JM38510/ 31303BCA	<a href="#">Samples</a>
M38510/31303BCA	ACTIVE	CDIP	J	14	25	Non-RoHS & Green	SNPB	N / A for Pkg Type	-55 to 125	JM38510/ 31303BCA	<a href="#">Samples</a>
M38510/31303BCA	ACTIVE	CDIP	J	14	25	Non-RoHS & Green	SNPB	N / A for Pkg Type	-55 to 125	JM38510/ 31303BCA	<a href="#">Samples</a>
SN54LS132J	ACTIVE	CDIP	J	14	25	Non-RoHS & Green	SNPB	N / A for Pkg Type	-55 to 125	SN54LS132J	<a href="#">Samples</a>
SN54LS132J	ACTIVE	CDIP	J	14	25	Non-RoHS & Green	SNPB	N / A for Pkg Type	-55 to 125	SN54LS132J	<a href="#">Samples</a>
SN54S132J	ACTIVE	CDIP	J	14	25	Non-RoHS & Green	SNPB	N / A for Pkg Type	-55 to 125	SN54S132J	<a href="#">Samples</a>
SN54S132J	ACTIVE	CDIP	J	14	25	Non-RoHS & Green	SNPB	N / A for Pkg Type	-55 to 125	SN54S132J	<a href="#">Samples</a>
SN74LS132D	LIFEBUY	SOIC	D	14	50	RoHS & Green	NIPDAU	Level-1-260C-UNLIM	0 to 70	LS132	
SN74LS132D	LIFEBUY	SOIC	D	14	50	RoHS & Green	NIPDAU	Level-1-260C-UNLIM	0 to 70	LS132	
SN74LS132DR	ACTIVE	SOIC	D	14	2500	RoHS & Green	NIPDAU	Level-1-260C-UNLIM	0 to 70	LS132	<a href="#">Samples</a>
SN74LS132DR	ACTIVE	SOIC	D	14	2500	RoHS & Green	NIPDAU	Level-1-260C-UNLIM	0 to 70	LS132	<a href="#">Samples</a>
SN74LS132N	ACTIVE	PDIP	N	14	25	RoHS & Green	NIPDAU	N / A for Pkg Type	0 to 70	SN74LS132N	<a href="#">Samples</a>
SN74LS132N	ACTIVE	PDIP	N	14	25	RoHS & Green	NIPDAU	N / A for Pkg Type	0 to 70	SN74LS132N	<a href="#">Samples</a>
SN74LS132NSR	ACTIVE	SO	NS	14	2000	RoHS & Green	NIPDAU	Level-1-260C-UNLIM	0 to 70	74LS132	<a href="#">Samples</a>

Orderable Device	Status (1)	Package Type	Package Drawing	Pins	Package Qty	Eco Plan (2)	Lead finish/ Ball material (6)	MSL Peak Temp (3)	Op Temp (°C)	Device Marking (4/5)	Samples
SN74LS132NSR	ACTIVE	SO	NS	14	2000	RoHS & Green	NIPDAU	Level-1-260C-UNLIM	0 to 70	74LS132	<a href="#">Samples</a>
SNJ54LS132FK	ACTIVE	LCCC	FK	20	55	Non-RoHS & Green	SNPB	N / A for Pkg Type	-55 to 125	SNJ54LS132FK	<a href="#">Samples</a>
SNJ54LS132FK	ACTIVE	LCCC	FK	20	55	Non-RoHS & Green	SNPB	N / A for Pkg Type	-55 to 125	SNJ54LS132FK	<a href="#">Samples</a>
SNJ54LS132J	ACTIVE	CDIP	J	14	25	Non-RoHS & Green	SNPB	N / A for Pkg Type	-55 to 125	7600401CA SNJ54LS132J	<a href="#">Samples</a>
SNJ54LS132J	ACTIVE	CDIP	J	14	25	Non-RoHS & Green	SNPB	N / A for Pkg Type	-55 to 125	7600401CA SNJ54LS132J	<a href="#">Samples</a>
SNJ54LS132W	ACTIVE	CFP	W	14	25	Non-RoHS & Green	SNPB	N / A for Pkg Type	-55 to 125	7600401DA SNJ54LS132W	<a href="#">Samples</a>
SNJ54LS132W	ACTIVE	CFP	W	14	25	Non-RoHS & Green	SNPB	N / A for Pkg Type	-55 to 125	7600401DA SNJ54LS132W	<a href="#">Samples</a>
SNJ54S132FK	ACTIVE	LCCC	FK	20	55	Non-RoHS & Green	SNPB	N / A for Pkg Type	-55 to 125	SNJ54S132FK	<a href="#">Samples</a>
SNJ54S132FK	ACTIVE	LCCC	FK	20	55	Non-RoHS & Green	SNPB	N / A for Pkg Type	-55 to 125	SNJ54S132FK	<a href="#">Samples</a>
SNJ54S132J	ACTIVE	CDIP	J	14	25	Non-RoHS & Green	SNPB	N / A for Pkg Type	-55 to 125	SNJ54S132J	<a href="#">Samples</a>
SNJ54S132J	ACTIVE	CDIP	J	14	25	Non-RoHS & Green	SNPB	N / A for Pkg Type	-55 to 125	SNJ54S132J	<a href="#">Samples</a>
SNJ54S132W	ACTIVE	CFP	W	14	25	Non-RoHS & Green	SNPB	N / A for Pkg Type	-55 to 125	SNJ54S132W	<a href="#">Samples</a>
SNJ54S132W	ACTIVE	CFP	W	14	25	Non-RoHS & Green	SNPB	N / A for Pkg Type	-55 to 125	SNJ54S132W	<a href="#">Samples</a>

(1) The marketing status values are defined as follows:

**ACTIVE:** Product device recommended for new designs.

**LIFEBUY:** TI has announced that the device will be discontinued, and a lifetime-buy period is in effect.

**NRND:** Not recommended for new designs. Device is in production to support existing customers, but TI does not recommend using this part in a new design.

**PREVIEW:** Device has been announced but is not in production. Samples may or may not be available.

**OBSELETE:** TI has discontinued the production of the device.

(2) **RoHS:** TI defines "RoHS" to mean semiconductor products that are compliant with the current EU RoHS requirements for all 10 RoHS substances, including the requirement that RoHS substance do not exceed 0.1% by weight in homogeneous materials. Where designed to be soldered at high temperatures, "RoHS" products are suitable for use in specified lead-free processes. TI may reference these types of products as "Pb-Free".

**RoHS Exempt:** TI defines "RoHS Exempt" to mean products that contain lead but are compliant with EU RoHS pursuant to a specific EU RoHS exemption.

**Green:** TI defines "Green" to mean the content of Chlorine (Cl) and Bromine (Br) based flame retardants meet JS709B low halogen requirements of <=1000ppm threshold. Antimony trioxide based flame retardants must also meet the <=1000ppm threshold requirement.

(3) MSL, Peak Temp. - The Moisture Sensitivity Level rating according to the JEDEC industry standard classifications, and peak solder temperature.

(4) There may be additional marking, which relates to the logo, the lot trace code information, or the environmental category on the device.

(5) Multiple Device Markings will be inside parentheses. Only one Device Marking contained in parentheses and separated by a "~" will appear on a device. If a line is indented then it is a continuation of the previous line and the two combined represent the entire Device Marking for that device.

(6) Lead finish/Ball material - Orderable Devices may have multiple material finish options. Finish options are separated by a vertical ruled line. Lead finish/Ball material values may wrap to two lines if the finish value exceeds the maximum column width.

**Important Information and Disclaimer:**The information provided on this page represents TI's knowledge and belief as of the date that it is provided. TI bases its knowledge and belief on information provided by third parties, and makes no representation or warranty as to the accuracy of such information. Efforts are underway to better integrate information from third parties. TI has taken and continues to take reasonable steps to provide representative and accurate information but may not have conducted destructive testing or chemical analysis on incoming materials and chemicals. TI and TI suppliers consider certain information to be proprietary, and thus CAS numbers and other limited information may not be available for release.

In no event shall TI's liability arising out of such information exceed the total purchase price of the TI part(s) at issue in this document sold by TI to Customer on an annual basis.

**OTHER QUALIFIED VERSIONS OF SN54LS132, SN74LS132 :**

- Catalog : [SN74LS132](#)
- Military : [SN54LS132](#)

NOTE: Qualified Version Definitions:

- Catalog - TI's standard catalog product
- Military - QML certified for Military and Defense Applications

**TAPE AND REEL INFORMATION**

**QUADRANT ASSIGNMENTS FOR PIN 1 ORIENTATION IN TAPE**

\*All dimensions are nominal

Device	Package Type	Package Drawing	Pins	SPQ	Reel Diameter (mm)	Reel Width W1 (mm)	A0 (mm)	B0 (mm)	K0 (mm)	P1 (mm)	W (mm)	Pin1 Quadrant
SN74LS132DR	SOIC	D	14	2500	330.0	16.4	6.5	9.0	2.1	8.0	16.0	Q1
SN74LS132NSR	SO	NS	14	2000	330.0	16.4	8.2	10.5	2.5	12.0	16.0	Q1

**TAPE AND REEL BOX DIMENSIONS**

\*All dimensions are nominal

Device	Package Type	Package Drawing	Pins	SPQ	Length (mm)	Width (mm)	Height (mm)
SN74LS132DR	SOIC	D	14	2500	356.0	356.0	35.0
SN74LS132NSR	SO	NS	14	2000	356.0	356.0	35.0



**TUBE**

\*All dimensions are nominal

Device	Package Name	Package Type	Pins	SPQ	L (mm)	W (mm)	T (μm)	B (mm)
7600401DA	W	CFP	14	1	506.98	26.16	6220	NA
SN74LS132D	D	SOIC	14	50	506.6	8	3940	4.32
SN74LS132N	N	PDIP	14	25	506	13.97	11230	4.32
SN74LS132N	N	PDIP	14	25	506	13.97	11230	4.32
SNJ54LS132FK	FK	LCCC	20	55	506.98	12.06	2030	NA
SNJ54LS132W	W	CFP	14	1	506.98	26.16	6220	NA
SNJ54S132FK	FK	LCCC	20	55	506.98	12.06	2030	NA

# MECHANICAL DATA

NS (R-PDSO-G\*\*)

PLASTIC SMALL-OUTLINE PACKAGE

14-PINS SHOWN



- NOTES:
- A. All linear dimensions are in millimeters.
  - B. This drawing is subject to change without notice.
  - C. Body dimensions do not include mold flash or protrusion, not to exceed 0,15.

W (R-GDFP-F14)

CERAMIC DUAL FLATPACK



- NOTES:
- A. All linear dimensions are in inches (millimeters).
  - B. This drawing is subject to change without notice.
  - C. This package can be hermetically sealed with a ceramic lid using glass frit.
  - D. Index point is provided on cap for terminal identification only.
  - E. Falls within MIL STD 1835 GDFP1-F14

## GENERIC PACKAGE VIEW

**FK 20**

**LCCC - 2.03 mm max height**

8.89 x 8.89, 1.27 mm pitch

LEADLESS CERAMIC CHIP CARRIER

This image is a representation of the package family, actual package may vary.  
Refer to the product data sheet for package details.



4229370VA\

J 14

**GENERIC PACKAGE VIEW**  
**CDIP - 5.08 mm max height**  
CERAMIC DUAL IN LINE PACKAGE



Images above are just a representation of the package family, actual package may vary.  
Refer to the product data sheet for package details.

4040083-5/G

J0014A



# PACKAGE OUTLINE

CDIP - 5.08 mm max height

CERAMIC DUAL IN LINE PACKAGE



4214771/A 05/2017

**NOTES:**

1. All controlling linear dimensions are in inches. Dimensions in brackets are in millimeters. Any dimension in brackets or parenthesis are for reference only. Dimensioning and tolerancing per ASME Y14.5M.
2. This drawing is subject to change without notice.
3. This package is hermetically sealed with a ceramic lid using glass frit.
4. Index point is provided on cap for terminal identification only and on press ceramic glass frit seal only.
5. Falls within MIL-STD-1835 and GDIP1-T14.

# EXAMPLE BOARD LAYOUT

J0014A

CDIP - 5.08 mm max height

CERAMIC DUAL IN LINE PACKAGE



LAND PATTERN EXAMPLE  
NON-SOLDER MASK DEFINED  
SCALE: 5X



4214771/A 05/2017

D (R-PDSO-G14)

PLASTIC SMALL OUTLINE



- NOTES:
- A. All linear dimensions are in inches (millimeters).
  - B. This drawing is subject to change without notice.
  -  Body length does not include mold flash, protrusions, or gate burrs. Mold flash, protrusions, or gate burrs shall not exceed 0.006 (0,15) each side.
  -  Body width does not include interlead flash. Interlead flash shall not exceed 0.017 (0,43) each side.
  - E. Reference JEDEC MS-012 variation AB.



D (R-PDSO-G14)

PLASTIC SMALL OUTLINE



4211283-3/E 08/12

- NOTES:
- All linear dimensions are in millimeters.
  - This drawing is subject to change without notice.
  - Publication IPC-7351 is recommended for alternate designs.
  - Laser cutting apertures with trapezoidal walls and also rounding corners will offer better paste release. Customers should contact their board assembly site for stencil design recommendations. Refer to IPC-7525 for other stencil recommendations.
  - Customers should contact their board fabrication site for solder mask tolerances between and around signal pads.

N (R-PDIP-T\*\*)

PLASTIC DUAL-IN-LINE PACKAGE

16 PINS SHOWN



- NOTES:
- A. All linear dimensions are in inches (millimeters).
  - B. This drawing is subject to change without notice.
  - (C) Falls within JEDEC MS-001, except 18 and 20 pin minimum body length (Dim A).
  - (D) The 20 pin end lead shoulder width is a vendor option, either half or full width.

## IMPORTANT NOTICE AND DISCLAIMER

TI PROVIDES TECHNICAL AND RELIABILITY DATA (INCLUDING DATA SHEETS), DESIGN RESOURCES (INCLUDING REFERENCE DESIGNS), APPLICATION OR OTHER DESIGN ADVICE, WEB TOOLS, SAFETY INFORMATION, AND OTHER RESOURCES "AS IS" AND WITH ALL FAULTS, AND DISCLAIMS ALL WARRANTIES, EXPRESS AND IMPLIED, INCLUDING WITHOUT LIMITATION ANY IMPLIED WARRANTIES OF MERCHANTABILITY, FITNESS FOR A PARTICULAR PURPOSE OR NON-INFRINGEMENT OF THIRD PARTY INTELLECTUAL PROPERTY RIGHTS.

These resources are intended for skilled developers designing with TI products. You are solely responsible for (1) selecting the appropriate TI products for your application, (2) designing, validating and testing your application, and (3) ensuring your application meets applicable standards, and any other safety, security, regulatory or other requirements.

These resources are subject to change without notice. TI grants you permission to use these resources only for development of an application that uses the TI products described in the resource. Other reproduction and display of these resources is prohibited. No license is granted to any other TI intellectual property right or to any third party intellectual property right. TI disclaims responsibility for, and you will fully indemnify TI and its representatives against, any claims, damages, costs, losses, and liabilities arising out of your use of these resources.

TI's products are provided subject to [TI's Terms of Sale](#) or other applicable terms available either on [ti.com](https://www.ti.com) or provided in conjunction with such TI products. TI's provision of these resources does not expand or otherwise alter TI's applicable warranties or warranty disclaimers for TI products.

TI objects to and rejects any additional or different terms you may have proposed.

Mailing Address: Texas Instruments, Post Office Box 655303, Dallas, Texas 75265  
Copyright © 2023, Texas Instruments Incorporated